

LOWER UNIT BREAKDOWN

Model:
QS370
QSB370
QSP370

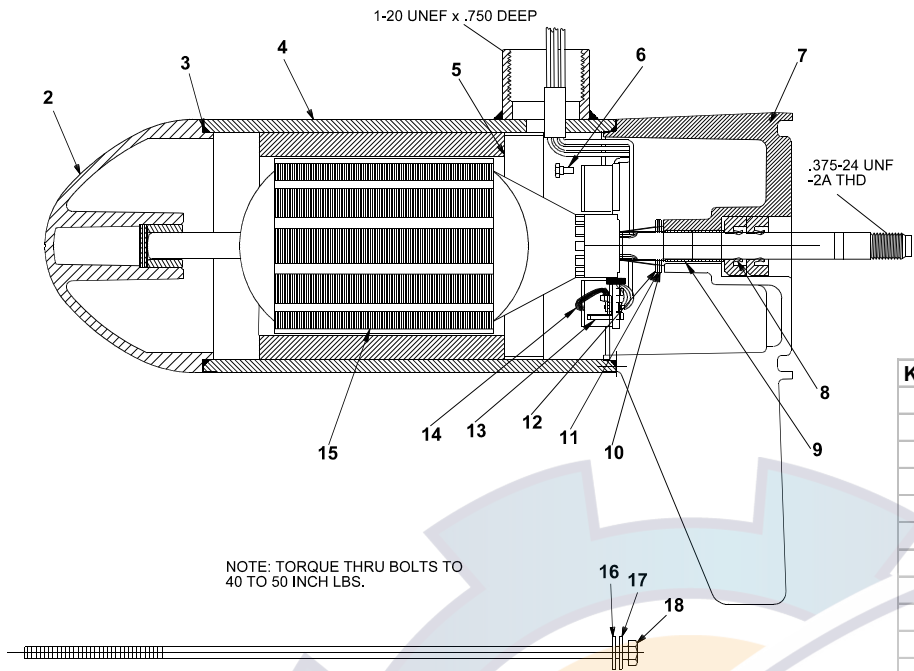

KEY #	QTY	DESCRIPTION	PART NO.
1	X	MOTOR	DF397-02
2	1	NOSE CAP	JF3212-01
3	2	O RING SEAL	MR217-01
4	1	HOUSING ASSY	JF3210-01
5	1	RETAINER	JF233-01
6	2	BRUSH CARD SCREW	MR228-01
7	1	COMM CAP	DF3205-01
8	2	SHAFT SEAL	MR223-01
9	1	BEARING	MR206-01
10	1	NYLATRON WASHER	MR226-01
11	1	WASHER	MR227-01
12	1	E RING	MR219-01
13	2	BRUSH SPRINGS	MR214-02
14	1	BRUSH ASSY LESS SPRING	DF3201-01
15	1	ARMATURE 3.5"	CF3207-01
16	4	STATIC SEAL	MR222-01
17	4	THRU BOLT WASHER	MR216-01
18	2	THRU BOLT	MR218-02

WIRING

